

Genuine Accessories



Vehicle Model: Multiple

Model Year Multiple

Part No. G2F41 AU001

Language English

Rev. Date 8/18/2020

Accessory: Wheel Locks

Difficulty: (A)

Note: Difficulty stated above reflects the minimum level of expertise required to install the accessory:











- (A) Customer
- (B) Dealer Technician
- (C) Master Technician or Specialist

Application Notes

Alloy Wheels Only

Wheel Locks must not be applied to steel wheels or the temporary spare tire.

Instructional Symbols / Definitions

 Denotes warnings that may lead to serious physical injury or vehicle damage	 Denotes quality processes to be checked prior to moving to the next step	Denotes personal protective equipment (PPEs) that may be required for a step. Examples of safety equipment icons noted below:
 Denotes cautions to be taken to avoid physical injury or electronic component damage	 Denotes specific tools that are necessary to complete a step	 Glasses
 Denotes cautions to be taken to avoid vehicle and component damage	 Denotes important information to be reviewed during the step	 Gloves
		 Mask
		 Hearing Protection

Basic Required Tools

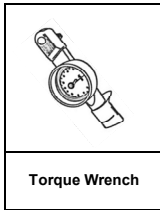
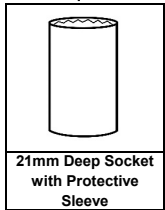

Part Weight (Gross)

0.88	lbs
0.40	kg

FMVSS 110 Compliance Information

All dealers must determine if the weight they have added in the form of all options or accessories, when added to the weight of all Port/Dealer Installed options or accessories, exceeds the lesser of 1.5% of GVWR or 100 lbs. If the additional weight does exceed the lesser of the indicated thresholds, a "Load Carrying Capacity Reduced" label must be installed. A black, fine-point, indelible marker must be used to write by hand onto the label, the reduced carrying capacity in kilograms or pounds, which is the total weight of all added options and accessories.
Load Label Part Number: NP070 - 09003

Notes to the installer:

- 1) Read the entire Installation Instructions prior to beginning the installation of the part.
- 2) If applicable, scan the barcode label located on the accessory part or packaging prior to installing, to register the part. If this accessory is installed as a replacement, register the removal of the old part before registering the new part. Old and new parts will have different barcode data, and the old registration cannot be reused.
- 3) Make sure the vehicle is completely clean and dry in the area(s) the part is to be installed.
- 4) Ensure the vehicle is properly protected in the area(s) that the accessory is to be installed.
- 5) NEVER place tools on painted surfaces, seating surfaces, dash pad, console or floor carpet/mats.
- 6) Always wear appropriate personal protective equipment, including gloves, safety glasses, etc., when required.



Genuine Accessories

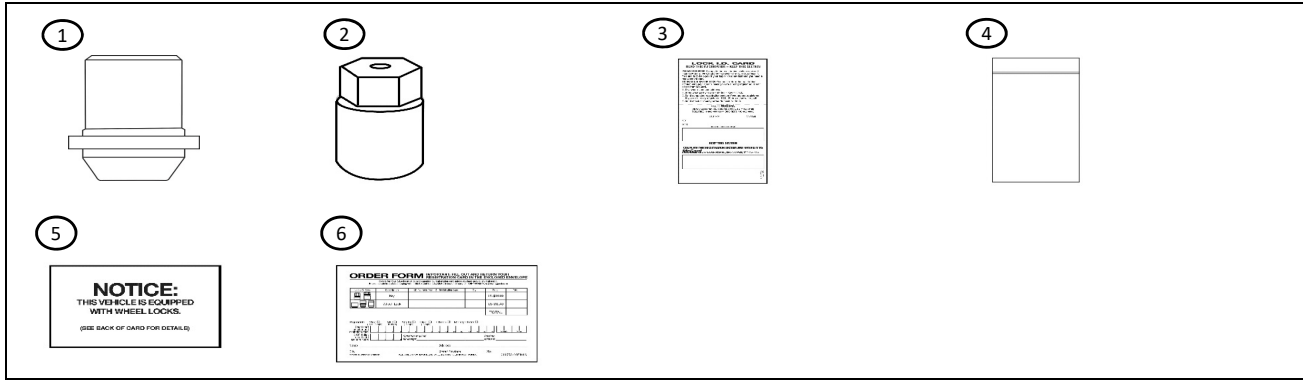

Kit Overview



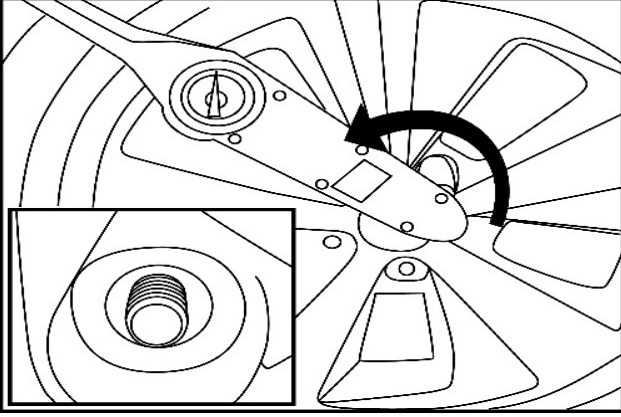

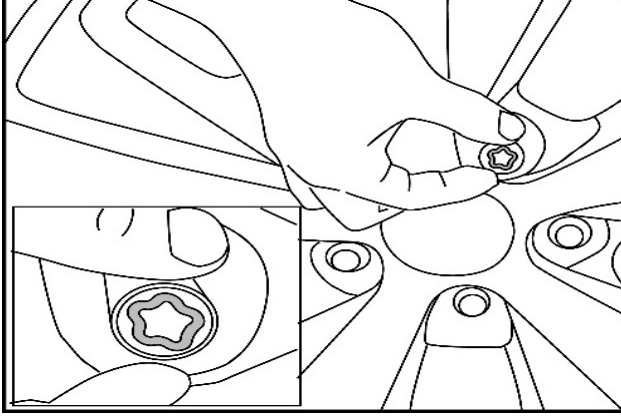

No.	Qty	Description	No.	Qty	Description
1	4	Wheel Lock	6	1	Order Form/Envelope
2	1	Key Assembly			
3	1	ID Card			
4	1	Zip Lock Bag			
5	1	Important Notice Card			

Genuine Accessories

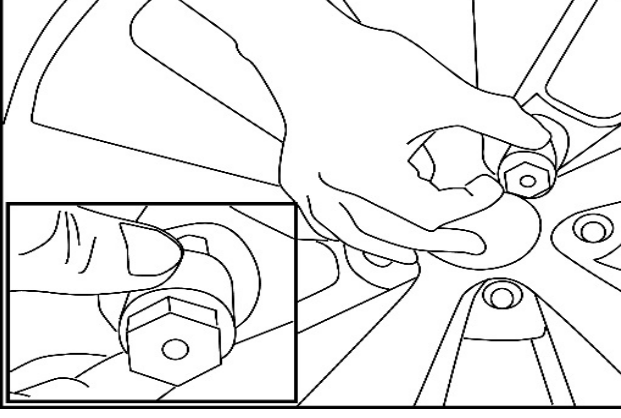
1	 21mm Deep Socket with Protective Sleeve and Torque Wrench
	
N O T E	<p>A. Remove one (1) lug nut from each wheel using a 21mm deep socket with protective sleeve. Do not allow the socket to scrape the wheel while removing the lug nuts.</p> <p>NOTE: A power tool or other suitable tool, may be used to remove the factory lug nut using a 21mm deep socket with protective sleeve.</p>
	<p>CAUTION: Make sure the socket does not scrape the wheel when removing lug nuts.</p>

2	
	
N O T E	<p>A. Before proceeding with wheel lock installation, verify and confirm the seating surface of the removed lug nuts match the seating surface of the wheel locks. Do NOT proceed with wheel lock installation if the seating surfaces do not match.</p> <p>B. By hand, install one (1) Wheel Lock onto each wheel.</p>
	<p>CAUTION: Use of an impact gun may cause permanent damage to the Wheel Lock and Wheel Lock Key.</p>

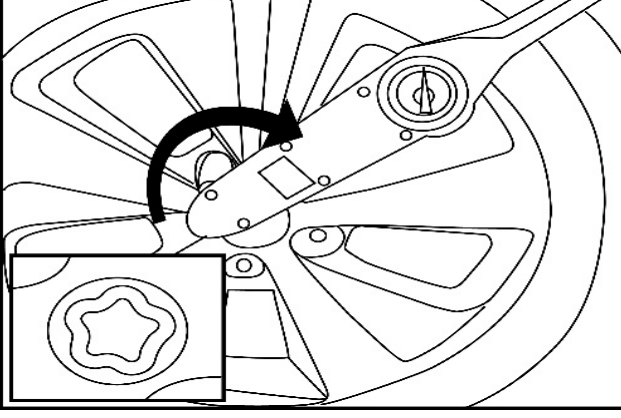
3	
	
N O T E	<p>A. Using the supplied Wheel Lock Key, place it on top of each Wheel Lock, turning until the Wheel Lock Key and Wheel Lock patterns engage.</p> <p>B. Tighten each Wheel Lock by hand. Do not use an impact gun.</p>
	<p>CAUTION: Use of an impact gun may cause permanent damage to the Wheel Lock and Wheel Lock Key.</p>

4	 21mm Deep Socket with Protective Sleeve and Torque Wrench
	
N O T E	<p>A. Using a torque wrench and 21 mm deep socket with protective sleeve, place the socket on the Wheel Lock Key, and while applying inward pressure, tighten to the factory torque specification for each Wheel Lock. Do not allow the socket to scrape the wheel while tightening.</p>
	<p>CAUTION: Use of an impact gun may cause permanent damage to the Wheel Lock and Wheel Lock Key.</p>

Genuine Accessories

5 

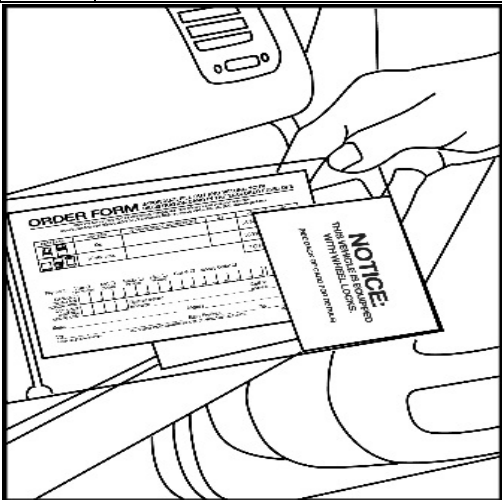

A. Place the supplied Important Notice Card, ID/Registration Card and Order Form/Envelope in the Plastic Zip Bag, and place it in the vehicle glove compartment.

NOTE

6 

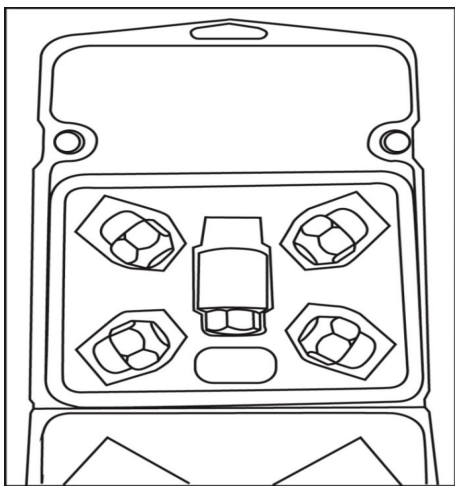

A. Store the Wheel Lock Key and the vehicle lug nuts removed in step 1, into the clamshell package.

NOTE

7 

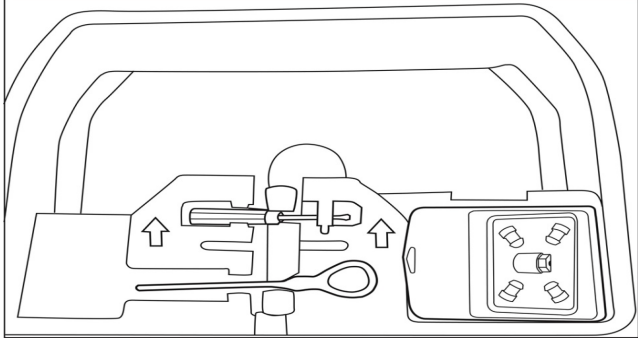
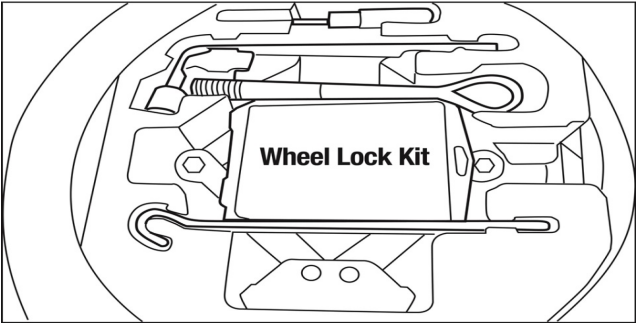





A. Place the clamshell package in the proper location near the factory lug nut wrench, typically found in the cargo area of the vehicle. Make sure the package is securely placed to avoid any rattles/noise.

NOTE

Genuine Accessories

Visual Check

Item to be Checked		Result	
	Make sure each Wheel Lock is torqued to the factory specification.	Wheel Locks torqued to factory specifications.	
	Make sure the Wheel Lock Key and vehicle lug nuts are properly stored in the clamshell package.	Wheel Lock Key and vehicle lug nuts properly stored.	
	Ensure clamshell package is securely placed to avoid any rattles/noise.	Clamshell is securely placed in vehicle.	