

Genuine Accessories



Vehicle Model: **Santa Fe**

Model Year 2019~
 Part No. S2F61 AU000 (DIO)
 S2F61 AU600 (PIO)
 Language English
 Rev. Date 4/18/2019

Accessory: **Tow Hitch**









Difficulty: (B)

Note: Difficulty stated above reflects the minimum level of expertise required to install the accessory:
 (A) Customer
 (B) Dealer Technician
 (C) Master Technician or Specialist



Application Notes

The Installation Instructions below include steps for **Tow Hitch Harness** and **Tow Hitch** installation procedure. Pay special attention to the upper right corner symbol "  " of each step if not installing both accessories jointly.

Instructional Symbols / Definitions

 Denotes warnings that may lead to serious physical injury or vehicle damage	 Denotes quality processes to be checked prior to moving to the next step	Denotes personal protective equipment (PPEs) that may be required for a step. Examples of safety equipment icons noted below:	
 Denotes cautions to be taken to avoid physical injury or electronic component damage	 Denotes specific tools that are necessary to complete a step	 Glasses	 Gloves
 Denotes cautions to be taken to avoid vehicle and component damage	NOTE Denotes important information to be reviewed during the step	 Mask	 Hearing Protection

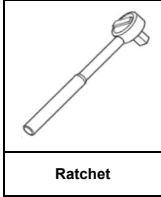
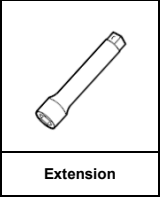
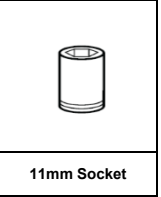
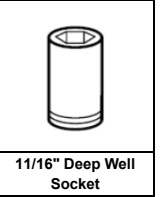
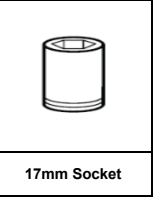
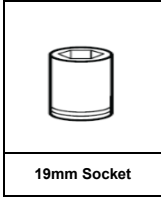
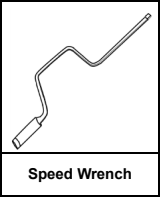
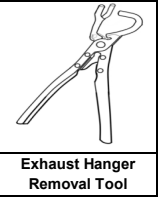
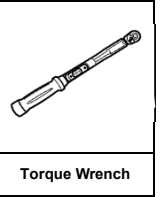
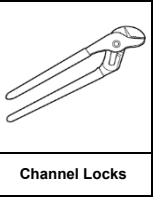
Basic Required Tools

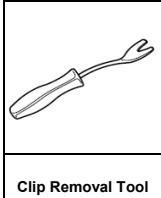
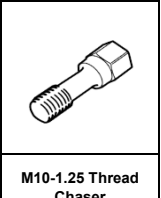
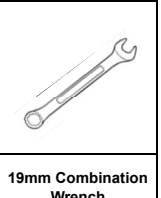
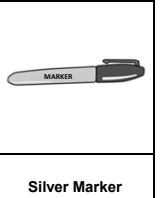
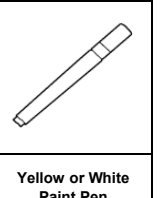
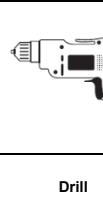
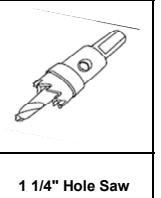
 Ratchet	 Extension	 11mm Socket	 11/16" Deep Well Socket	 17mm Socket		
 19mm Socket	 Speed Wrench	 Exhaust Hanger Removal Tool	 Torque Wrench	 Channel Locks	 Shears	
 Clip Removal Tool	 M10-1.25 Thread Chaser	 19mm Combination Wrench	 Silver Marker	 Yellow or White Paint Pen	 Drill	 1 1/4" Hole Saw

Specialty Required Tools

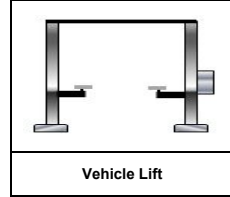
 Vehicle Lift
--

Part Weight (Gross)

44.36	lbs
20.12	kg

FMVSS 110 Compliance Information

All dealers must determine if the Net weight they have added in the form of all options or accessories, when added to the weight of all Port/Dealer Installed options or accessories, exceeds the lesser of 1.5% of GVWR or 100 lbs. If the additional weight does exceed the lesser of the indicated thresholds, a "Load Carrying Capacity Reduced" label must be installed. A black, fine-point, indelible marker must be used to write by hand onto the label, the reduced carrying capacity in kilograms or pounds, which is the total weight of all added options and accessories.
 Load Label Part Number: NP070 - 09003

Notes to the installer:

- 1) Read the entire Installation Instructions prior to beginning the installation of this accessory.
- 2) Make sure the vehicle is completely clean and dry in the area(s) the part is to be installed.
- 3) Ensure the vehicle is properly protected in the area(s) that the accessory is to be installed.
- 4) NEVER place tools on painted surfaces, seating surfaces, dash pad, console or floor carpet/mats.
- 5) Always wear appropriate personal protective equipment, including gloves, safety glasses, etc., when required.
- 6) Roll down the driver's window and adjust the power seats (if applicable) prior to disconnecting battery power, if needed.
- 7) Record radio presets prior to disconnecting battery power, if needed.
- 8) Vehicle should be at room temperature.
- 9) The tow hitch mounting plates will flex until they seat against the vehicle's mounting points during the hardware torquing process in step 24.





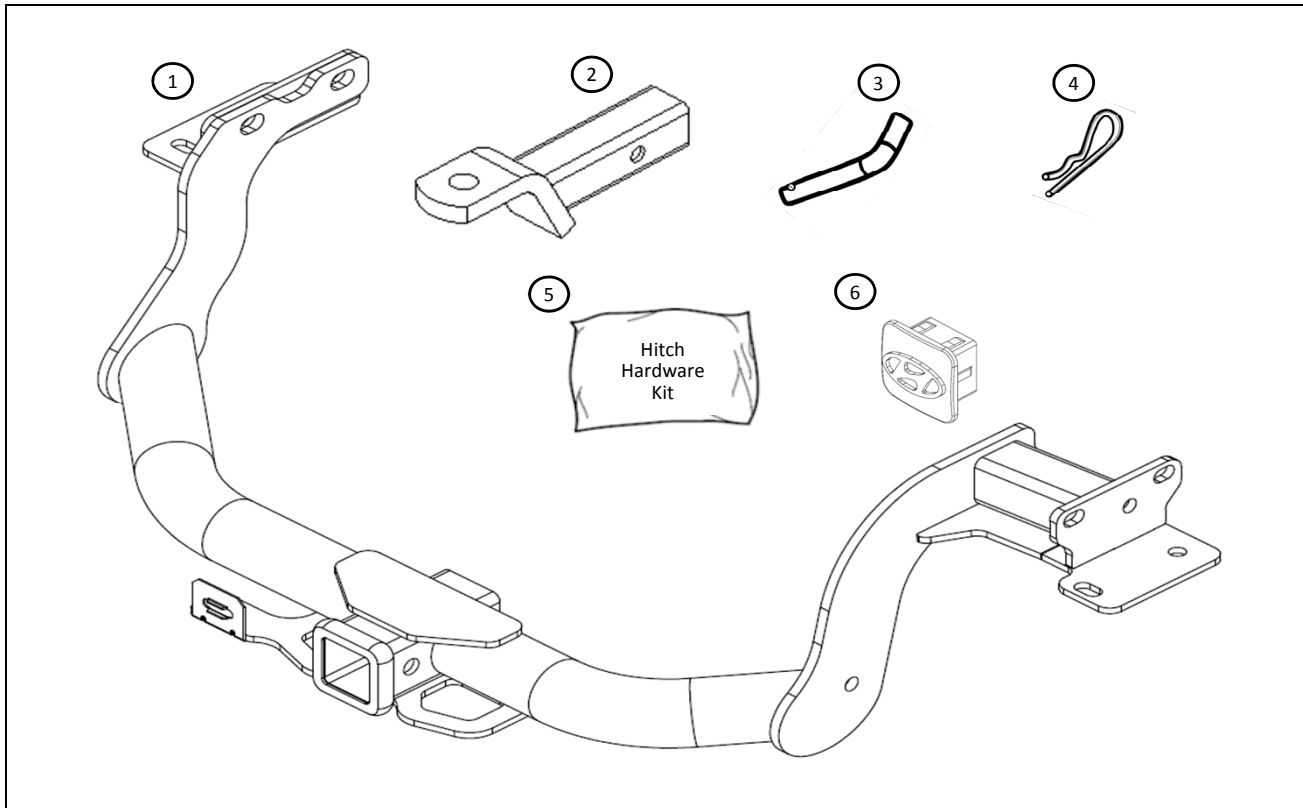

Genuine Accessories

Kit Overview

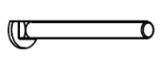

No.	Qty	Description	No.	Qty	Description	No.	Qty	Description
1	1	Hitch	3	1	Hitch Pin	5	1	Hitch Hardware Kit
2	1	Ball Mount	4	1	Hitch Pin Clip	6	1	Hitch Receiver Plug

Hardware Overview

A		B		C		D		E	
2	M12x120 Bolt	4	M12 Toothed Washer	2	M12 Hex Nut	2	7/16" x 4.5" Special Bolt	2	7/16" Toothed Washer
F		G		H					
2	7/16" Hex Nut	4	M10x30 Bolt	4	M10 Toothed Washer				





Follow instructions for proper placement of each component.



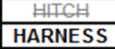
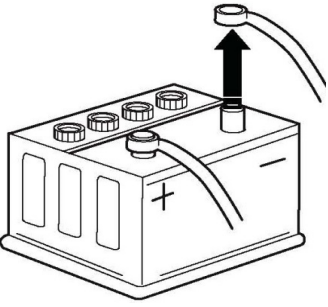

Hardware Total
22



Radio Presets - record customer preset frequencies if disconnecting battery power

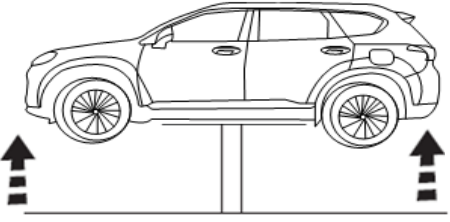

FM1 _____	FM2 _____	FM3 _____	FM4 _____	FM5 _____
FM6 _____	FM7 _____	FM8 _____	FM9 _____	FM10 _____
AM1 _____	AM2 _____	AM3 _____	AM4 _____	AM5 _____
SAT1 _____	SAT2 _____	SAT3 _____	SAT4 _____	SAT5 _____

Genuine Accessories

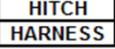
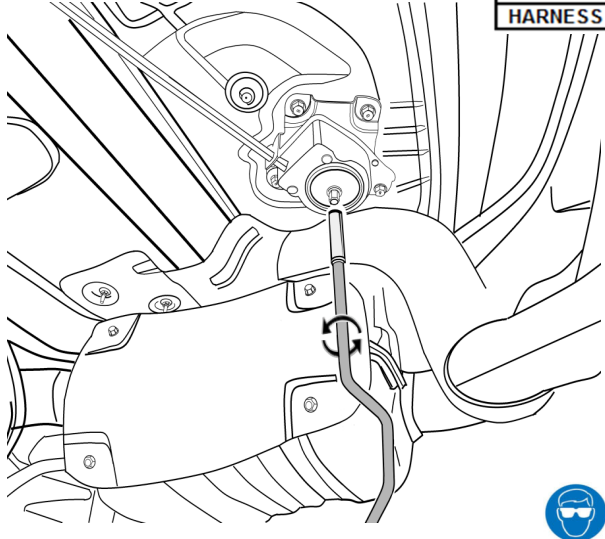

1		Ratchet, 10mm Deep Socket and Vehicle Lift
		
<p>Tow Hitch Harness Installation Procedure ONLY</p> 		
 		
N O T E	<p>A. Position the vehicle on a vehicle lift. B. Record any pre-set radio stations (if applicable). C. Open the vehicle's hood. D. Remove the Cap from Negative (-) Battery Cable. E. Disconnect and isolate the vehicle's Negative (-) Battery Cable. F. Raise vehicle to desired working height to access the under body at the rear bumper.</p>	
 <p>Warning! Shock Hazard. Do not touch vehicle's negative battery cable to the vehicle's positive battery cable. Serious injury and damage to the vehicle may occur.</p>		

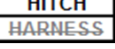
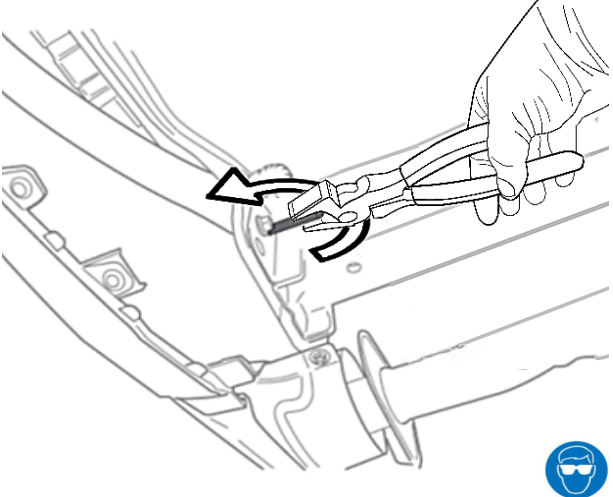

2		Vehicle Lift
		
<p>Tow Hitch Installation Procedure ONLY</p> 		
		
N O T E	<p>A. Position the vehicle on a vehicle lift. B. Raise vehicle to desired working height to access the under body at the rear bumper.</p>	
 <p>WARNING,; Ensure the vehicle is safely positioned on the lift prior to working under it.</p>		

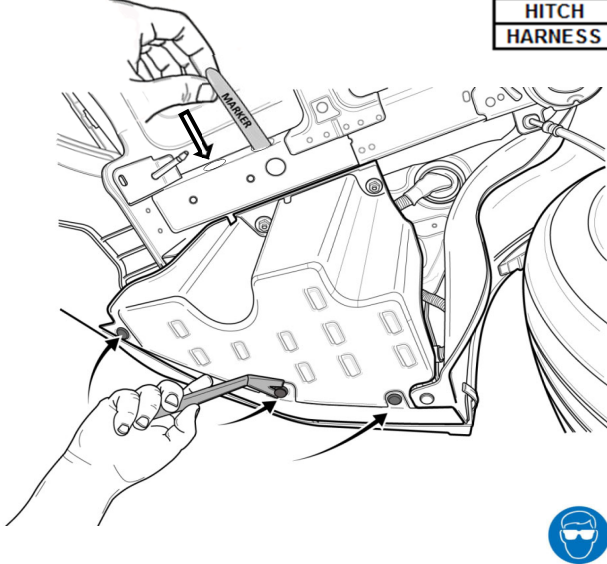

3		Speed Wrench and 11mm Socket
		
		
		
N O T E	<p>A. Using a speed wrench and 11mm socket, lower and remove the spare tire by loosening the spare tire carrier nut as shown. B. Store the spare tire in a safe location for reinstallation.</p>	

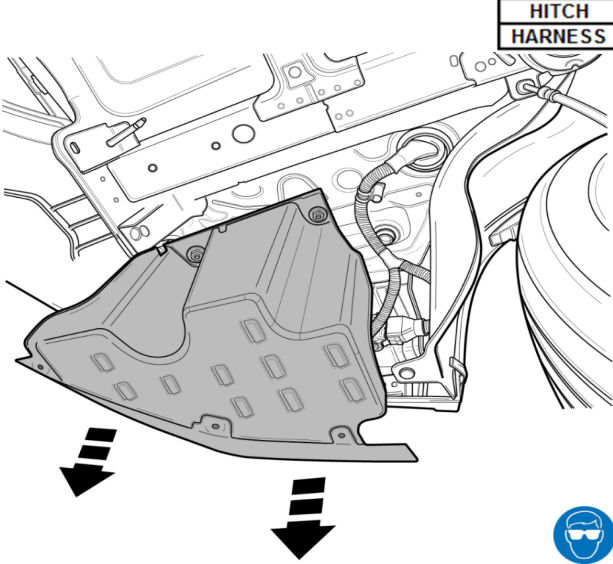

4		Channel Locks
		
		
		
N O T E	<p>A. Using channel locks, bend the end of the driver's side bumper locating pin towards the center of vehicle approximately 1".</p>	

Genuine Accessories

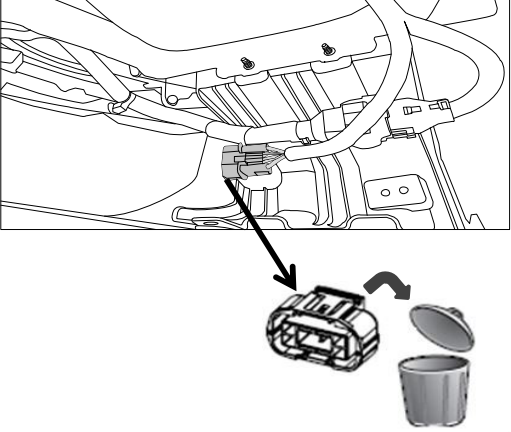
5		Silver Marker and Clip Removal Tool
		
N O T E	<p>Hitch Only:</p> <p>A. Insert a marker through two (2) holes in driver side frame rail to mark trim location on side plastic panel.</p> <p>Hitch & Harness:</p> <p>B. Using a clip removal tool, remove the three (3) lower plastic push clips on the driver side plastic cover.</p> <p>C. Store the three (3) plastic push clips in a safe location for reinstallation.</p>	

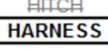
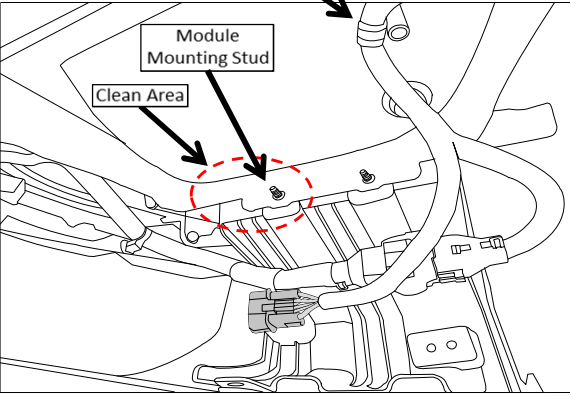

6		
		
N O T E	<p>A. Dislodge and remove the driver side plastic cover panel by pulling straight down.</p> <p>B. Ensure the two (2) upper plastic clips detach with the side plastic cover panel. If necessary, remove the two (2) upper plastic clips by hand.</p> <p>C. Store the removed parts in a safe location for reinstallation.</p>	



7		
		
N O T E	<p>A. Locate the factory 12-Pin harness with connector protective cover.</p> <p>B. Remove connector protective cover and discard.</p>	
		<p>CAUTION! Make sure connector is clean and free of any debris.</p>

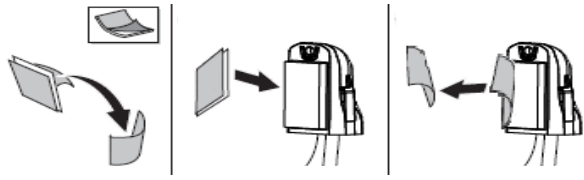

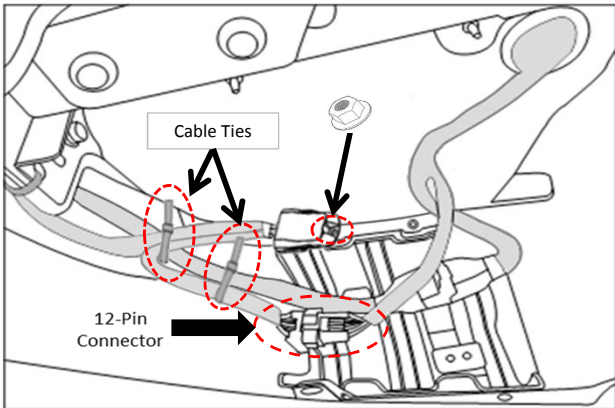
8		50/50 Isopropyl Alcohol (70%) & Water and Lint Free Cloth
<p>Previous Installation Instructions Module Mounting Location (see "Installation Instruction Notes" section on page 12)</p>		
		
N O T E	<p>A. Clean the surface area shown and allow to completely dry.</p> <p>NOTE: The rearmost stud shown will be used to secure the Tow Hitch Module.</p>	
		<p>Ensure the cleaned area is completely dry.</p>

Genuine Accessories

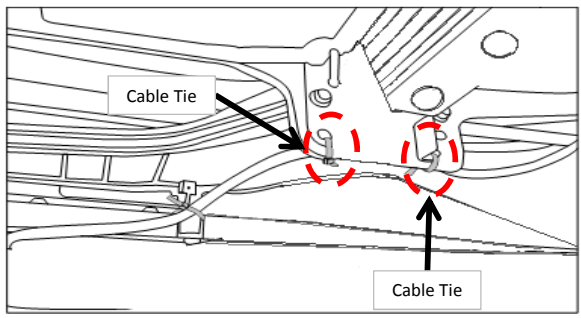
9		
HITCH HARNESS		
		
NOTE	<p>A. Attach the foam tape to the back side of the Tow Hitch Module as shown. B. Remove the back liner of the foam tape.</p>	

10		Ratchet, 10mm Deep Socket, Extension, Torque Wrench and Wire Cutters
HITCH HARNESS		
		
NOTE	<p>A. Secure the Tow Hitch Module to the rearmost stud with 10mm Nut as shown. Torque 10mm Nut to: 6.0 ~ 8.8 N.m (0.6 ~ 0.9 kgf.m, 52 ~ 78 lb-in). B. Connect Tow Hitch Harness 12-Pin Connector to the vehicle factory connector as shown. C. Using one (1) cable tie, secure the Tow Hitch harnesses bound together to the factory harness as shown. D. Using one (1) cable tie, secure the 12-Pin Connector harness to the factory harness as shown. E. Trim excess cable ties.</p>	
		
 Ensure the Connector is fully engaged.		

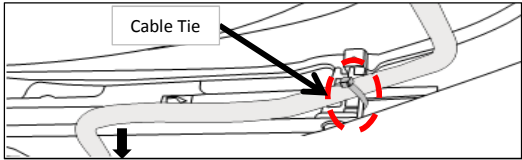
11		Wire Cutters
HITCH HARNESS		
		
NOTE	<p>A. Route the Tow Hitch Harness behind the rear bumper as shown. B. Using two (2) cable ties, secure the Tow Hitch Harness to vehicle's steel mounting holes as shown. C. Trim excess cable ties.</p>	
		

12		Wire Cutters
HITCH HARNESS		
		
NOTE	<p>A. Continue to route the harness along the rear bumper beam as shown. B. Using one (1) cable tie, secure the Tow Hitch Harness to the bumper beam bracket as shown. C. Trim excess cable tie.</p>	
		

Genuine Accessories

13 Exhaust Hanger Removal Tool

HITCH HARNESS

NOTE

A. Using an exhaust hanger removal tool, dislodge the two (2) exhaust hangers from the rubber holders.

14 Channel Locks

HITCH HARNESS

NOTE

A. Using channel locks, bend the end of the passenger side bumper locating pin towards the center of vehicle approximately 1".

15

HITCH HARNESS

NOTE

A. Remove and discard rubber plug from bottom driver's side frame rail as shown.



16

HITCH HARNESS

NOTE

A. Pass the two (2) M12 bolts through the frame to ensure that there are no blockages in the channels.
 B. Repeat the process on the passenger side using the two (2) 7/16" special bolts to ensure there are no blockages in the channels.

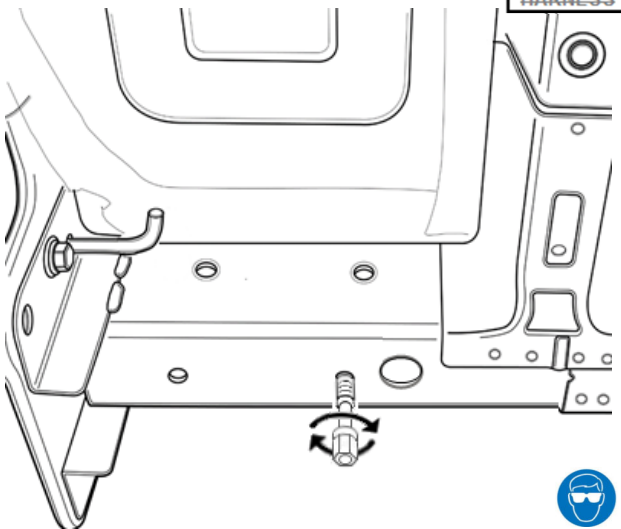
Genuine Accessories

17		M10-1.25 Thread Chaser	HITCH HARNESS
			
N O T E	<p>A. Before installing the hitch, confirm there is no debris or weld spatter in the chassis rail weld nuts. Confirm the four (4) M10 Bolts thread into the four (4) mounting holes of the frame rails.</p> <p>B. If needed, use an M10-1.25 thread chaser to clean out the weld nuts.</p>		
 Do not cross thread the M10-1.25" weld nut threads when chasing them.			

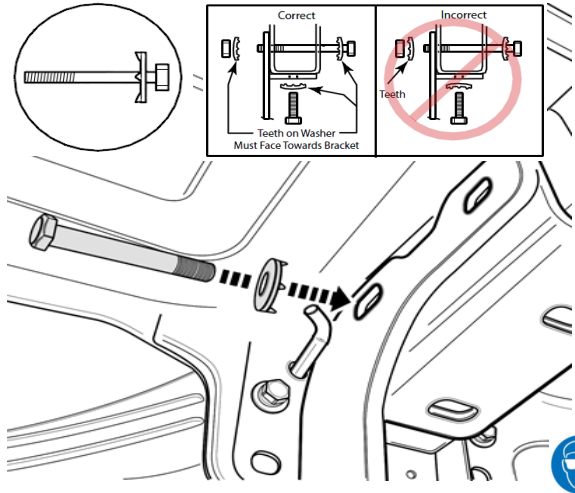
18			HITCH HARNESS
			
N O T E	<p>A. Preassemble one (1) M12 bolt with one (1) M12 toothed washer for driver side as shown above. Have a 7/16" special bolt for passenger side ready.</p> <p>NOTE: Make sure the 'toothed side' of washer is installed facing the hitch.</p> <p>B. Raise hitch under vehicle starting with raising the hitch over the muffler on the passenger side.</p> <p>C. Insert one (1) M12 bolt with one (1) M12 toothed washer on the driver side, as shown above.</p>		

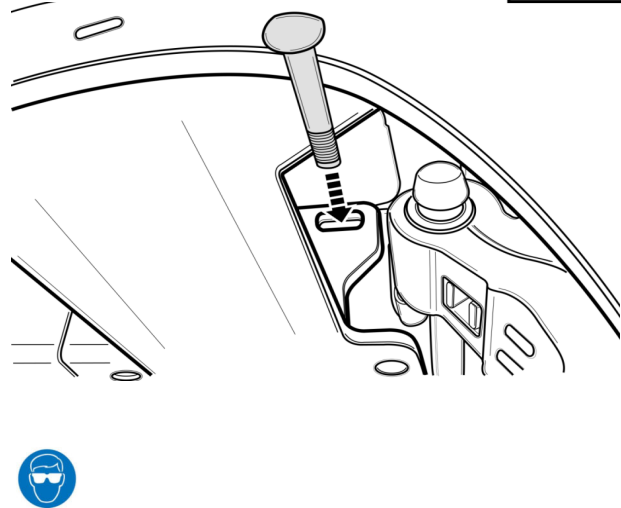
19			HITCH HARNESS
			
N O T E	<p>A. Insert one (1) 7/16" special bolt, flat side up, in passenger side.</p> <p>NOTE: Bolt must be inserted on the inside of the chassis rails. This will hold hitch in position.</p>		

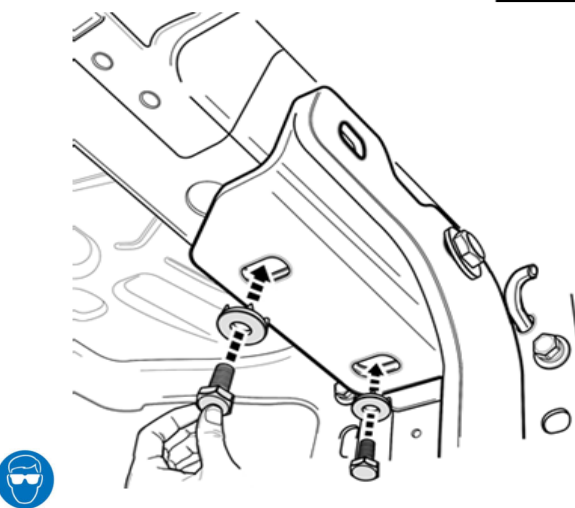
20			HITCH HARNESS
			
N O T E	<p>A. Starting on the passenger side forward hole, hand tighten one (1) M10 bolt with one (1) M10 toothed washer.</p> <p>NOTE: Make sure the 'toothed side' on each washer is installed facing the hitch.</p> <p>B. Repeat the procedure for the remaining three bolts.</p>		

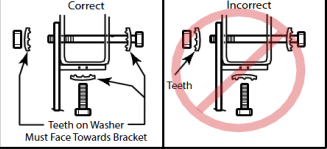
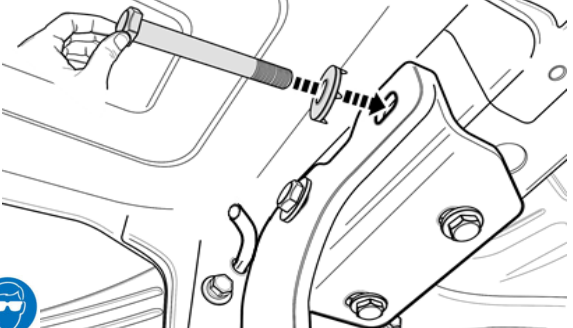
21		HITCH HARNESS
		
		
N O T E	<p>A. Install one (1) M12 bolt and one (1) M12 toothed washer into remaining upper attachment point on driver side frame rail. NOTE: Make sure the "toothed side" on the washer is installed facing the hitch.</p> <p>B. Install one (1) M12 hex nut & one (1) toothed washer onto two (2) M12 bolts on driver side & hand tighten. NOTE: Make sure the "toothed side" of the washers are installed against the frame.</p>	

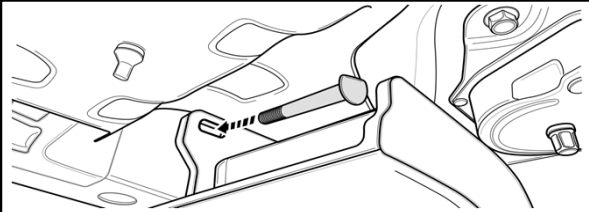
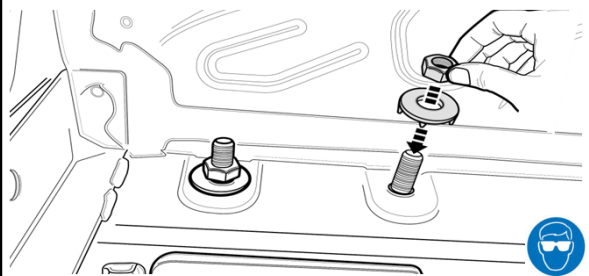
22		HITCH HARNESS
		
		
N O T E	<p>A. On the passenger side, install one (1) 7/16" special bolt, flat side up, into remaining front attachment point.</p> <p>B. Hand tighten one (1) 7/16" hex nut and one (1) 7/16" toothed washer onto two (2) bolts as shown. NOTE: Make sure the "toothed side" of the washer is installed against the frame.</p>	

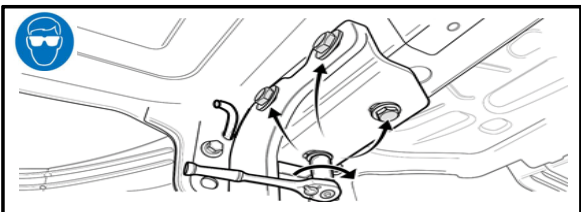
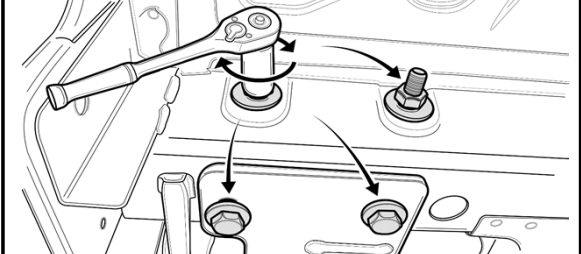
23		HITCH HARNESS
<p>Ratchet, 17mm Socket, 19mm Socket, 19mm Combination Wrench and 11/16" Deep Socket</p>		
		
		
N O T E	<p>A. Using a ratchet and 17mm socket, tighten the four (4) M10 Bolts until tow hitch makes contact with vehicle's frame rails. Do not torque bolts at this time.</p> <p>B. Using a ratchet and 11/16" deep socket, tighten the two (2) 7/16" special bolts until nut and washer become snug to vehicle's frame rail.</p> <p>C. Using a ratchet, 19mm socket and 19mm combination wrench, tighten the two (2) M12 Bolts until nut and washer become snug to vehicle's frame rail. NOTE: The gaps between the tow hitch mounting plates and the vehicle's frame rails are normal at this point in the installation. The tow hitch mounting plates will flex until they seat against the vehicle's mounting points during the hardware torquing process in the following step.</p>	

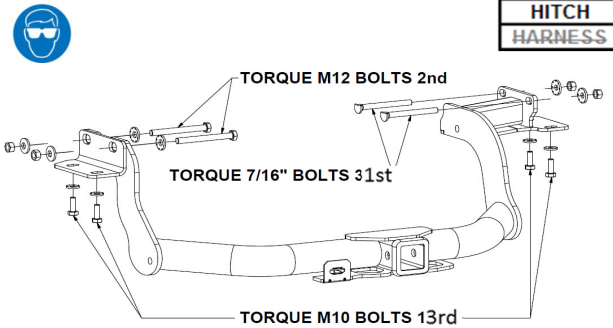
24		HITCH HARNESS
<p>Torque Wrench, Extension, 17mm Socket, 19mm Socket, 19mm Combination Wrench, 11/16" Deep Socket & Yellow or White Paint Pen</p>		
		
<p>Bolt Torque Sequence:</p> <ol style="list-style-type: none"> 1) Torque 7/16" bolts to 80 N·m (8.2 kgf·m, 59 lbf·ft) 2) Torque M12 bolts to 107 N·m (10.9 kgf·m, 79 lbf·ft) 3) Torque M10 bolts to 54 N·m (5.5 kgf·m, 40 lbf·ft) 		
N O T E	<p>A. Using an extension, 17mm socket, 19mm socket, 19mm combination wrench, 11/16" deep socket and torque wrench, tighten and torque all of the nuts and bolts. NOTE: Follow the bolt torque sequence as shown above.</p> <p>B. Repeat torque sequence to ensure bolts are tightened properly.</p> <p>C. Use a yellow or white paint pen to mark a line on top of each bolt head. NOTE: The paint line should go across the bolt head and onto the hitch or vehicle.</p>	

Genuine Accessories

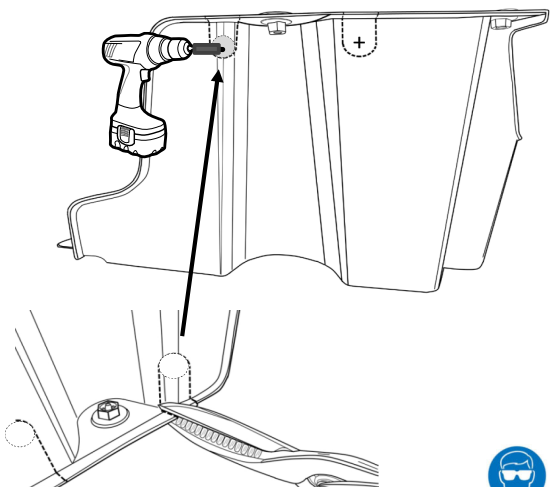

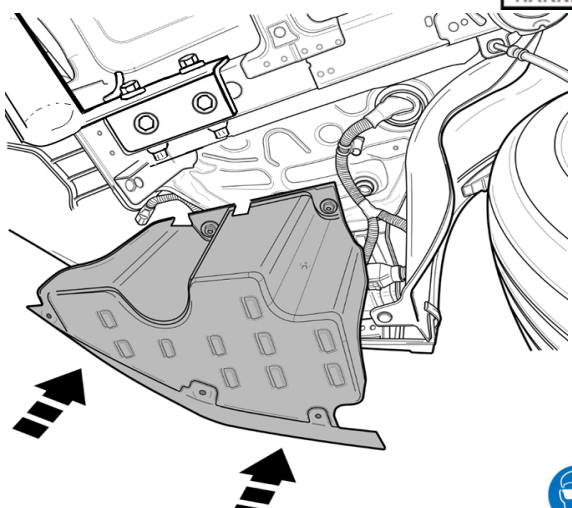
25		Drill, 1 1/4" Hole Saw and Shears	HITCH HARNESS
			
N O T E	<p>A. Using a drill with a 1 1/4" hole saw, drill a hole through the plastic panel at the two (2) marker marks created previously.</p> <p>B. Use straight shears to cut down from top edges of plastic panel to sides of holes, as shown above.</p>		

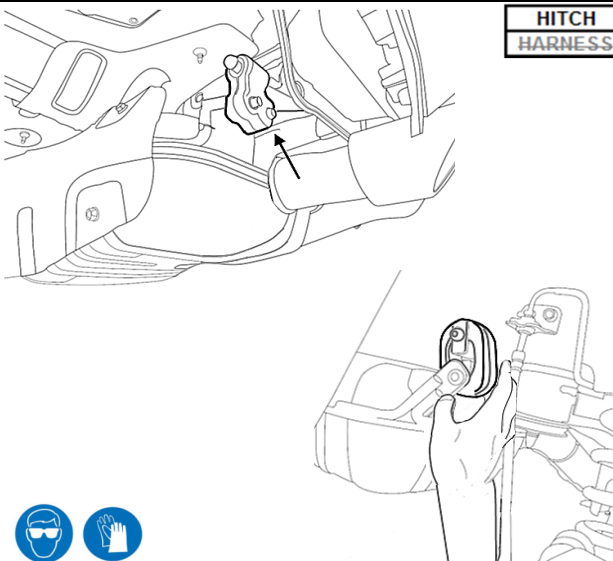
26			HITCH HARNESS
			
N O T E	<p>A. Reinstall the driver side plastic cover panel by aligning the upper plastic clips and pushing straight up.</p> <p>B. Reinstall the three (3) lower plastic push clips and the two (2) upper plastic clips.</p>		

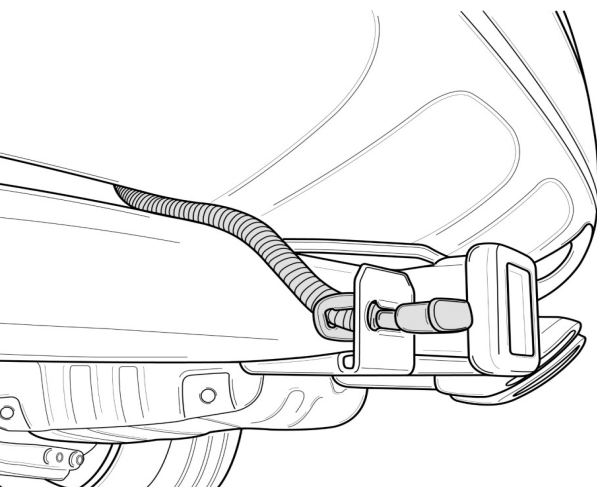
27			HITCH HARNESS
			
N O T E	<p>A. Reinstall the rubber muffler mounts back onto their bracket.</p> <p>B. Ensure they are fully seated back into their original position.</p>		

28			HITCH HARNESS
			
N O T E	<p>A. Route the Tow Hitch Harness 4-Flat Connector over the hitch and install connector through back side of bracket on the hitch.</p> <p>B. Make sure the Ground Pin is positioned towards the Driver Side of the vehicle.</p> <p>C. Push the 4-Flat connector through the hitch bracket until the first detent is visible and the connector is locked into position as shown.</p> <p>D. Secure the Cover over the 4-Flat connector.</p>		

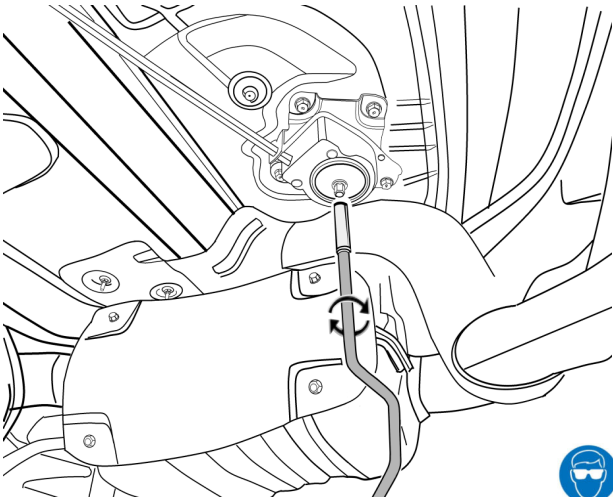
Genuine Accessories

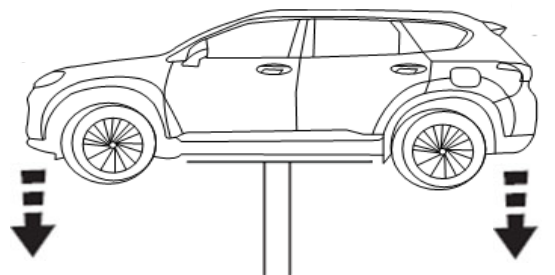

29	 Speed Wrench, 11mm Socket	HITCH HARNESS
		
N O T E	<p>A. Using the speed wrench and 11mm socket, raise the spare tire back into its original position.</p> <p>B. Visually confirm everything is reinstalled back onto the vehicle.</p>	
	Confirm spare tire is secured and seated properly.	

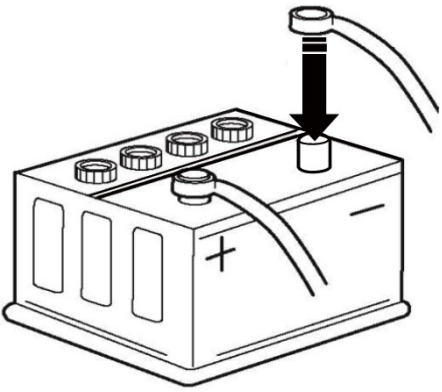
30	 Vehicle Lift	HITCH HARNESS
		
N O T E	<p>A. Lower the vehicle.</p>	

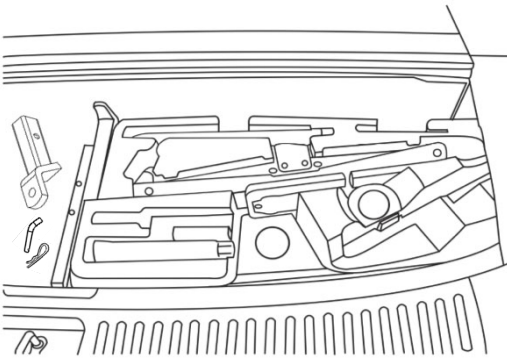
31	 Ratchet, 10mm Deep Socket and Torque Wrench	HITCH HARNESS
		
N O T E	<p>A. Reconnect the Vehicle's Negative (-) Battery Cable.</p> <p>B. Torque to: 5.0 ~ 6.0 N.m (0.5 ~ 0.6 kgf.m, 45 ~ 52 lb-in).</p> <p>C. Reinstall the Cap from Negative (-) Battery Cable.</p> <p>D. Close the vehicle's hood.</p> <p>E. Reprogram any pre-set radio stations (if applicable).</p>	

32		HITCH HARNESS
		
N O T E	<p>A. Place ball mount kit under cargo floorboard in the cargo storage compartment.</p>	





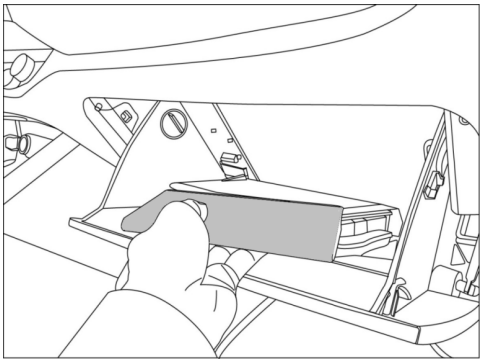



Genuine Accessories

33		12V Tester or Volt Meter
HITCH HARNESS		
		
NOTE	A. Perform Function Check at the end of the Instructions with a 12V Tester or Volt Meter.	

34		
HITCH HARNESS		
		
NOTE	A. Place the Caution Card into the Glove Box.	

Genuine Accessories

Visual Check

Item to be Checked		Result	
	Make sure four (4) M10 x 30 bolts are torqued to: 54 Nm (5.5 kgf-m, 40 lbf-ft).	The four (4) M10 x 30 bolts are torqued to: 54 Nm (5.5 kgf-m, 40 lbf-ft).	
	Make sure two (2) M12 x 120 bolts are torqued to: 107 Nm (10.9 kgf-m, 79 lbf-ft).	The two (2) M12 x 120 bolts are torqued to: 107 Nm (10.9 kgf-m, 79 lbf-ft).	
	Make sure two (2) 7/16" x 4.5" special bolts are torqued to: 80 Nm (8.2 kgf-m, 59 lbf-ft).	The Two (2) 7/16" x 4.5" special bolts are torqued to: 80 Nm (8.2 kgf-m, 59 lbf-ft).	
	Make sure all eight (8) bolts and surrounding tow hitch / chassis rail surfaces are marked using a paint pen.	All eight (8) bolts and surrounding tow hitch / chassis rail surfaces have paint line marks.	
	Make sure the muffler hangers are reinstalled properly.	Muffler hangers are reinstalled properly.	
	Make sure the driver side plastic panel is reinstalled properly.	The driver side plastic panel is reinstalled properly.	
	Make sure the spare tire is reinstalled and seated properly.	The spare tire is reinstalled and seated properly.	
	Make sure the ball mount box is placed under cargo floorboard in the cargo storage compartment.	Ball mount box is placed under cargo floorboard in the cargo storage compartment.	
	Make sure the 4-flat connector is mounted in hitch electrical bracket and weather cap is secured over connector.	The 4-flat connector is mounted in hitch electrical bracket and weather cap is secured over connector.	

Installation Instruction Notes

The mounting location of the Tow Hitch Module as changed from a previous version of the installation instructions. For service or inspection purposes, please note that either mounting location is acceptable.

Original Mounting Location

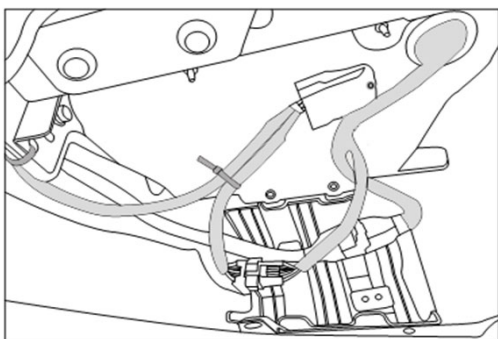

New Mounting Location

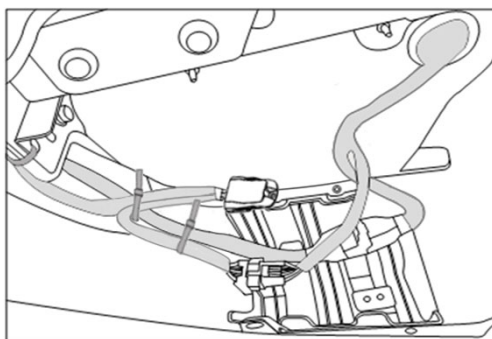

Genuine Accessories

Wiring Diagram

